

Lesson 13: The Volume of a Cylinder

Goals

- Calculate the volume of a cylinder, and compare and contrast (orally) the formula for volume of a cylinder with the formula for volume of a prism.
- Explain (orally) how to find the volume of a cylinder using the area of the base and height of the cylinder.

Learning Targets

- I can find the volume of a cylinder in mathematical and real-world situations.
- I know the formula for volume of a cylinder.

Lesson Narrative

In this lesson students learn that the volume of a cylinder is the area of the base times the height, just like a prism. This is accomplished by considering 1-unit-tall layers of a rectangular prism side by side with 1-unit-tall layers of a cylinder. After thinking about how to compute the volume of specific cylinders, students learn the general formulas $V = Bh$ and $V = \pi r^2 h$.

In the warm-up, students recall that a circle's area can be determined given its radius or diameter. Students also become familiar with what is meant by *radius* and *height* as those terms apply to cylinders. Finally, students compute the volume of a cylinder by multiplying the area of its base by its height. A volume expressed using the exact number π versus the same volume computed using 3.14 as an approximation for π is discussed. The following lesson provides opportunities to practice these skills and solve related problems.

Alignments

Building On

- 6.G.A.2: Find the volume of a right rectangular prism with fractional edge lengths by packing it with unit cubes of the appropriate unit fraction edge lengths, and show that the volume is the same as would be found by multiplying the edge lengths of the prism. Apply the formulas $V = lwh$ and $V = bh$ to find volumes of right rectangular prisms with fractional edge lengths in the context of solving real-world and mathematical problems.
- 7.G.B.4: Know the formulas for the area and circumference of a circle and use them to solve problems; give an informal derivation of the relationship between the circumference and area of a circle.

Addressing

- 8.G.C.9: Know the formulas for the volumes of cones, cylinders, and spheres and use them to solve real-world and mathematical problems.

Instructional Routines

- MLR1: Stronger and Clearer Each Time
- MLR3: Clarify, Critique, Correct
- MLR8: Discussion Supports
- Think Pair Share

Required Materials

Colored pencils

Required Preparation

A good way to manage the various formulas in this unit is to create a display for each formula as each one is introduced. Frequently draw students' attention to the displays and use them as a reference.

For the Circular Volumes activity, consider building a rectangular prism from 48 snap cubes to match the diagram in the print statement.

Provide access to colored pencils.

Student Learning Goals

Let's explore cylinders and their volumes.

13.1 A Circle's Dimensions

Warm Up: 10 minutes

The purpose of this warm-up is for students to review how to compute the area of a circle. This idea should have been carefully developed in grade 7. This warm-up gives students an opportunity to revisit this idea in preparation for finding the volume of a cylinder later in the lesson.

Students begin the activity with a whole-class discussion in which they identify important features of a circle including its radius and diameter. They use this information and the formula for the area of the circle to choose expressions from a list that are equivalent to the area of the circle. In the final question, students are given the area of the circle and find the corresponding radius.

As students are working, monitor for students who can explain why 16π , $\pi 4^2$, and "approximately 50" square units represent the area of the circle.

Building On

- 7.G.B.4

Launch

Display the diagram from the task statement for all to see and ask students:

- “Name a segment that is a radius of circle A.” (AC, AD, and AB or those with the letters reversed are all radii.) Review the meaning of the radius of a circle.
- “What do we call a segment like BC, with endpoints on the circle that contains the center of the circle?” (A diameter.) Review the meaning of a diameter of a circle.
- “What is the length of segment AB ?” (4 units.) Review the fact that all radii of a circle have the same length.

Give students 3 minutes of quiet work time and follow with a whole-class discussion.

Anticipated Misconceptions

If students struggle to recall how to find the area of a circle, encourage them to look up a formula using any available resources.

Student Task Statement

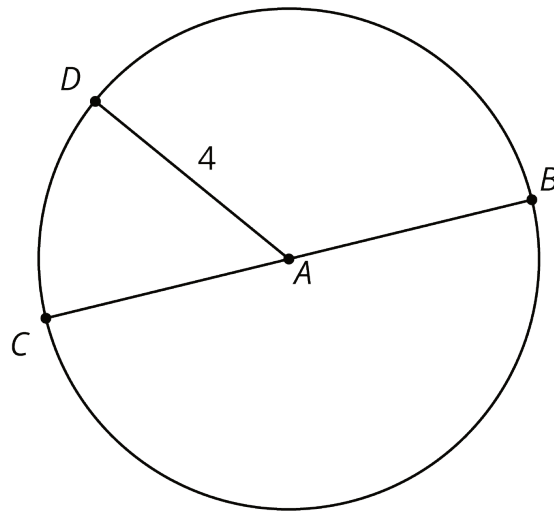

Here is a circle. Points A , B , C , and D are drawn, as well as Segments AD and BC .

1. What is the area of the circle, in square units? Select all that apply.
 - a. 4π
 - b. $\pi 8$
 - c. 16π
 - d. $\pi 4^2$
 - e. approximately 25
 - f. approximately 50
2. If the area of a circle is 49π square units, what is its radius? Explain your reasoning.

Student Response

1. c, d, and f. Since the radius is 4, the area of the circle is $\pi \cdot 4^2 = 16\pi$. This is approximately 50.3 square units.
2. 7 units. The square of the radius is 49 since the area is π times the square of the radius, and the area is 49π square units. The radius is 7 units, because $49 = 7^2$.

Activity Synthesis

The purpose of this discussion is to make sure students remember that the area of a circle can be found by squaring its radius and multiplying by π .

Select previously identified students to share answers to the first question and explain why each of the solutions represents the area of the circle. If not brought up during the discussion, tell students that sometimes it is better to express an area measurement in terms of π . Other times it may be better to use an approximation of π , like 3.14, to represent the area measurement in decimal form. In this unit, we will often express our answers in terms of π .

Display in a prominent place for all to see for the next several lessons: Let A be the area of a circle of radius r , then $A = \pi r^2$.

13.2 Circular Volumes

15 minutes

The purpose of this activity is for students to connect their previous knowledge of the volume of rectangular prisms to their understanding of the volume of cylinders. From previous work, students should know that the volume of rectangular prisms is found by multiplying the area of the base by the height. Here we expand upon that to compute the volume of a cylinder.

Students start by calculating the volume of a rectangular prism. Then they extrapolate from that to calculate the volume of a cylinder given the area of its base and its height. If some students don't know they should multiply the area of the base by its height, then they are prompted to connect prisms and cylinders to make a reasonable guess.

We want students to conjecture that the volume of a cylinder is the area of its base multiplied by its height.

Building On

- 6.G.A.2

Addressing

- 8.G.C.9

Instructional Routines

- MLR1: Stronger and Clearer Each Time

- Think Pair Share

Launch

Arrange students in groups of 2. Remind students that a rectangular prism has a base that is a rectangle, and a cylinder has a base that is a circle. It may have been some time since students have thought about the meaning of a result of a volume computation. Consider showing students a rectangular prism built from 48 snap cubes with the same dimensions as Figure A. It may help them to see that one layer is made of 16 cubes. Give students 3–5 minutes of quiet work time followed by a partner discussion. During their discussion, partners compare the volumes they found for the cylinders. If they guessed the volumes, partners explain their reasoning to one another. Follow with a whole-class discussion.

Access for Students with Disabilities

Representation: Develop Language and Symbols. Use virtual or concrete manipulatives to connect symbols to concrete objects or values. Provide connecting cubes for students to create rectangular prisms and calculate the volume of. Ask students to represent the volume of the rectangular prism in an equation and connect the base, width, and height to the 3-D model.

Supports accessibility for: Visual-spatial processing; Conceptual processing

Student Task Statement

What is the volume of each figure, in cubic units? Even if you aren't sure, make a reasonable guess.

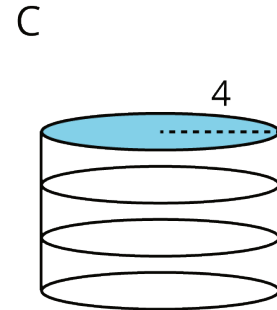
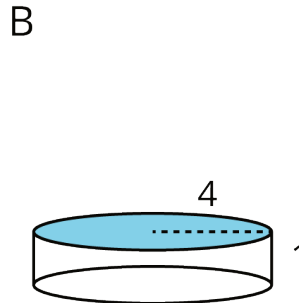
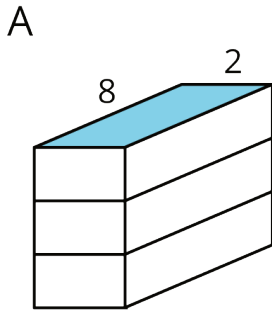

1. Figure A: A rectangular prism whose base has an area of 16 square units and whose height is 3 units.
2. Figure B: A cylinder whose base has an area of 16π square units and whose height is 1 unit.
3. Figure C: A cylinder whose base has an area of 16π square units and whose height is 3 units.

Student Response

1. 48 cubic units. The area of the rectangular base is 16, which is multiplied by the height 3 to find the volume.
2. 16π cubic units. The area of the circular base is $\pi \cdot 4^2$, which is multiplied by the height 1 to find the volume.
3. 48π cubic units. The area of the circular base is $\pi \cdot 4^2$, which is multiplied by the height 3 to find the volume.

Are You Ready for More?

prism	prism	prism	cylinder
base: square	base: hexagon	base: octagon	base: circle

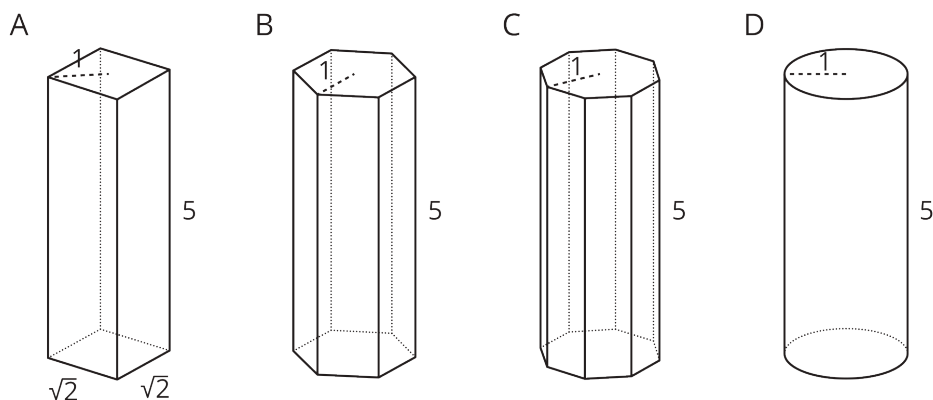

Here are solids that are related by a common measurement. In each of these solids, the distance from the center of the base to the furthest edge of the base is 1 unit, and the height of the solid is 5 units. Use 3.14 as an approximation for π to solve these problems.

1. Find the area of the square base and the circular base.
2. Use these areas to compute the volumes of the rectangular prism and the cylinder. How do they compare?
3. Without doing any calculations, list the figures from smallest to largest by volume. Use the images and your knowledge of polygons to explain your reasoning.
4. The area of the hexagon is approximately 2.6 square units, and the area of the octagon is approximately 2.83 square units. Use these areas to compute the volumes of the prisms with the hexagon and octagon bases. How does this match your explanation to the previous question?

Student Response

1. Area of the square is 2 square units. Area of the circle is approximately 3.14 square units.

2. Volume of the rectangular prism is 10 cubic units. Volume of the cylinder is 15.7 cubic units.
3. Answers vary. Sample response: the area of the polygons increase as the number of sides increase. This means that the volumes will also increase, since the height stays the same.
4. Volume of the hexagonal prism is 13 cubic units. Volume of the octagonal prism is 14.15 cubic units.

Activity Synthesis

Highlight the important features of cylinders and their definitions: the radius of the cylinder is the radius of the circle that forms its base; the height of a cylinder is the length between its circular top and bottom; a cylinder of height 1 can be thought of as a “layer” in a cylinder with height h . To highlight the connection between finding the area of a rectangular prism and finding the area of a cylinder, ask:

- “How are prisms and cylinders different?” (A prism has a base that is a polygon, and a cylinder has a base that is a circle.)
- “How are prisms and cylinders the same?” (The volume of cylinders and prisms is found by multiplying the area of the base by the height. $V = Bh$)
- “How do you find the area of the base, B , of a cylinder?” ($B = \pi r^2$).

Access for English Language Learners

Writing, Conversing: MLR1 Stronger and Clearer Each Time. Use this routine to give students a structured opportunity to revise a response to the question, “What is similar and different about cylinders and rectangular prisms?” Ask each student to meet with 2–3 other partners in a row for feedback. Provide student with prompts for feedback that will help students strengthen their ideas and clarify their language (e.g., “Can you give an example?”, “Why do you think that?”, “Can you say more about ...?”, etc.). Students can borrow ideas and language from each partner to strengthen their final explanation.

Design Principle(s): Optimize output (for explanation)

13.3 A Cylinder's Dimensions

Optional: 10 minutes

In this optional activity, students use colored pencils (or pens or highlighters) to label the radius and height on different pictures of cylinders. Then they sketch their own cylinders and label the radius and heights of those. The purpose of this activity is for students to practice identifying the radius and height of various cylinders, some of which are in context.

This activity can also be abbreviated if students demonstrate prior understanding of how to draw or label cylinders and only need a brief refresh.

Addressing

- 8.G.C.9

Instructional Routines

- MLR3: Clarify, Critique, Correct

Launch

Distribute colored pencils. Give students 1–2 minutes of quiet work time followed by a whole-class discussion.

Anticipated Misconceptions

In diagrams D and E, some students might mistake the diameter for the height of the cylinder. Some students may mark a height taller than the cylinder due to the tilt of the figure.

Student Task Statement

1. For cylinders A–D, sketch a radius and the height. Label the radius with an r and the height with an h .

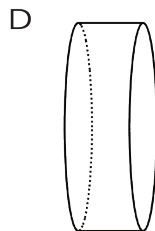
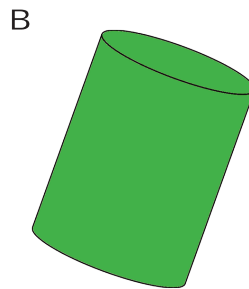
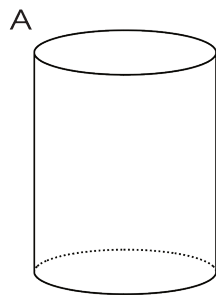

2. Earlier you learned how to sketch a cylinder. Sketch cylinders for E and F and label each one's radius and height.

Student Response

1. Answers vary.
2. Answers vary.

Activity Synthesis

Select students to share where they marked the radius and height and the cylinders sketched for images E and F. Discuss examples of other cylinders students see in real life.

Access for English Language Learners

Speaking, Listening: MLR3 Clarify, Critique, Correct. Present an incorrect drawing that reflects a possible misunderstanding from the class about the height of a cylinder. For example, draw a cylinder with the diameter incorrectly placed at its height and the height at its diameter. Prompt students to identify the error, (e.g., ask, “Do you agree with the representation? Why or why not?”), correct the representation, and write feedback to the author explaining the error. This helps students develop an understanding and make sense of identifying the heights of differently-oriented cylinders.

Design Principle(s): Support sense-making; Maximize meta-awareness

13.4 A Cylinder's Volume

10 minutes

The purpose of this activity is to give students opportunities to find the volumes of some cylinders. By finding the area of the base before finding the volume, students are encouraged to compute the volume by multiplying the area of its base by its height. This way of thinking about volume might be more intuitive for students than the formula $V = \pi r^2 h$. Notice students who plug the radius into a formula for the volume and students who find the area of the base and multiply that by the cylinder's height.

The second problem of this activity focuses on exploring cylinders in a context. Generally, the volume of a container is the amount of space inside, but in this context, that also signifies the amount of material that fits into the space. Students are not asked to find the area of the base of the silo. Notice students that find the area before computing the volume and those that use the volume formula and solve for it directly. Notice at what step in the computations students approximate π .

When working with problems in a given context, it is sometimes convenient or practical to use an approximation of π . An example of this is given in the question regarding the volume of a grain silo and interpretations of the answer.

Addressing

- 8.G.C.9

Instructional Routines

- MLR8: Discussion Supports

Launch

Provide access to colored pencils to shade the cylinder's base. Give students 5–6 minutes of quiet work time followed by a whole-class discussion.

Access for Students with Disabilities

Representation: Internalize Comprehension. Provide appropriate reading accommodations and supports to ensure students access to written directions, word problems and other text-based content.

Supports accessibility for: Language; Conceptual processing

Anticipated Misconceptions

Students might use the silo's diameter instead of the radius to find the volume. Remind them of the formula for area of a circle and the discussion about diameter and radius earlier in this lesson.

Student Task Statement

1. Here is a cylinder with height 4 units and diameter 10 units.

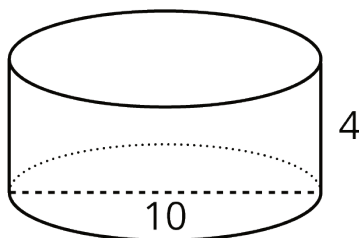

- a. Shade the cylinder's base.
 - b. What is the area of the cylinder's base? Express your answer in terms of π .
 - c. What is the volume of this cylinder? Express your answer in terms of π .
2. A silo is a cylindrical container that is used on farms to hold large amounts of goods, such as grain. On a particular farm, a silo has a height of 18 feet and diameter of 6 feet. Make a sketch of this silo and label its height and radius. How many cubic feet of grain can this silo hold? Use 3.14 as an approximation for π .

Student Response

1.
 - a. The image of the cylinder should have either its top or bottom shaded in.
 - b. 25π . The radius of the base is half of 10 or 5 units. The area of the base is 25π square units since $\pi 5^2 = 25\pi$.
 - c. 100π . The volume of the cylinder is the area of its base times its height, which is 100π cubic units, since $25\pi \cdot 4 = 100\pi$.

2. Approximately 509 cubic feet. The diameter of the silo's base is 6 feet, which means the base has a radius of 3 feet. The area of the base of the silo is 9π square feet. $\pi 3^2 = 9\pi$. The volume is 162π cubic feet ($18 \cdot 9\pi = 162\pi$). Using $\pi \approx 3.14$, the volume of the silo is approximately 509 cubic feet.

Are You Ready for More?

One way to construct a cylinder is to take a rectangle (for example, a piece of paper), curl two opposite edges together, and glue them in place.

Which would give the cylinder with the greater volume: Gluing the two dashed edges together, or gluing the two solid edges together?

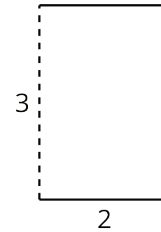

Student Response

Gluing the two solid edges together will create a cylinder with the greater volume.

Whichever two lines are glued together become the height of the cylinder, and the other lines represent the circumference of the circular base. For the cylinder created by gluing the dashed lines together, the height is 3 units, and the circumference is 2 units. Since circumference of a circle is equal to π times the diameter, the radius of the circular base must be $\frac{1}{2} \left(\frac{2}{\pi} \right) = \frac{1}{\pi}$. Therefore, the volume can be determined by $V = \pi \left(\frac{1}{\pi} \right)^2 (3)$, which is about .95 units³.

For the cylinder created by gluing the solid lines together, the height is 2 units, and the radius is $\frac{1}{2} \left(\frac{3}{\pi} \right) = \frac{3}{2\pi}$. Therefore, the volume can be determined by $V = \pi \left(\frac{3}{2\pi} \right)^2 (2)$, which is about 1.43 units³.

Activity Synthesis

The goal of this discussion is to ensure students understand how to use the area of the cylinder's base to calculate its volume. Consider asking the following questions:

- "How does knowing the area of a circular base help determine the volume of a cylinder?" (The volume is this area multiplied by the height of the cylinder.)
- "If the cylinder were on its side, how do you know which measurements to use for the volume?" (Since we need area of the base first, the radius or diameter of the circle will always be the measurement used for r , and the height is always the distance between the bases, or the measurement perpendicular to the bases. It doesn't matter which direction the cylinder is turned.)

- “When is it better to use approximations of pi instead of leaving it exact?” (Approximating pi helps us interpret an answer that has pi as a factor, like the area of a circular region or the volume of a cylindrical container.)

Access for English Language Learners

Speaking: MLR8 Discussion Supports. Use this routine to support whole-class discussion. For each response that is shared, ask students to restate and/or revoice what they heard using mathematical language. Consider providing students time to restate what they hear to a partner, before selecting one or two students to share with the class. Ask the original speaker if their peer was accurately able to restate their thinking. Call students' attention to any words or phrases that helped to clarify the original statement. This will help students produce and make sense of the language needed to communicate about different strategies for calculating volume of cylinders.

Design Principle(s): Support sense-making; Optimize output (for explanation)

Lesson Synthesis

Make a display that includes the formula for a cylinder's volume, $V = Bh$, along with a labeled diagram of a cylinder. This display should be kept posted in the classroom for the remaining lessons within this unit.

Previously, students computed the volume of prisms by multiplying the area of the base by the prism's height. To help students summarize the ideas in this lesson, ask “How is finding the volume of a cylinder like finding the volume of a prism?” and give students 2–3 minutes to write a response. Encourage students to use diagrams to show their thinking. Invite students to share their ideas, displaying any diagrams for all to see.

13.5 Liquid Volume

Cool Down: 5 minutes

Students compute the volume of a cylinder given its height and radius. Students are given the dimensions of the cylinder and the units.

Addressing

- 8.G.C.9

Student Task Statement

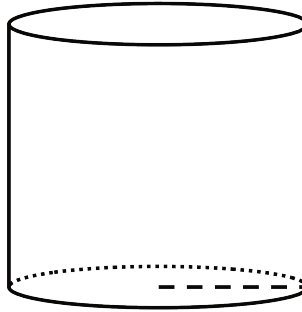

The cylinder shown here has a height of 7 centimeters and a radius of 4 centimeters.

1. What is the area of the base of the cylinder? Express your answer in terms of π .
2. How many cubic centimeters of fluid can fill this cylinder? Express your answer in terms of π .
3. Give a decimal approximation of your answer to the second question using 3.14 to approximate π .

Student Response

1. $16\pi \text{ cm}^2$. The square of the radius of the base is $4^2 = 16$, which is multiplied by π ($\pi \cdot 4^2 = 16\pi$).
2. $112\pi \text{ cm}^3$. The height of the cylinder is 7, which is multiplied by the area of the base ($16\pi \cdot 7 = 112\pi$).
3. 351.68 cm^3 , because $112 \cdot 3.14 \approx 351.68$

Student Lesson Summary

We can find the volume of a cylinder with radius r and height h using two ideas we've seen before:

- The volume of a rectangular prism is a result of multiplying the area of its base by its height.
- The base of the cylinder is a circle with radius r , so the base area is πr^2 .

Remember that π is the number we get when we divide the circumference of any circle by its diameter. The value of π is approximately 3.14.

Just like a rectangular prism, the volume of a cylinder is the area of the base times the height. For example, take a cylinder whose radius is 2 cm and whose height is 5 cm.

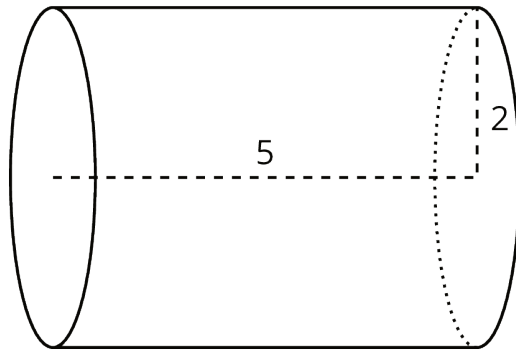

The base has an area of $4\pi \text{ cm}^2$ (since $\pi \cdot 2^2 = 4\pi$), so the volume is $20\pi \text{ cm}^3$ (since $4\pi \cdot 5 = 20\pi$). Using 3.14 as an approximation for π , we can say that the volume of the cylinder is approximately 62.8 cm^3 .

In general, the base of a cylinder with radius r units has area πr^2 square units. If the height is h units, then the volume V in cubic units is

$$V = \pi r^2 h$$

Lesson 13 Practice Problems

Problem 1

Statement

- Sketch a cylinder.
- Label its radius 3 and its height 10.
- Shade in one of its bases.

Solution

Answers vary.

Problem 2

Statement

At a farm, animals are fed bales of hay and buckets of grain. Each bale of hay is in the shape a rectangular prism. The base has side lengths 2 feet and 3 feet, and the height is 5 feet. Each bucket of grain is a cylinder with a diameter of 3 feet. The height of the bucket is 5 feet, the same as the height of the bale.

- Which is larger in area, the rectangular base of the bale or the circular base of the bucket? Explain how you know.
- Which is larger in volume, the bale or the bucket? Explain how you know.

Solution

- The bucket's base. The area of the bale's base is 6 square feet. The area of the bucket's base is just over 7 square feet, because $\pi(1.5)^2 \approx 7.07$.
- The bucket. The bale and the bucket have the same height, and the bucket's base area is larger.

Problem 3

Statement

Three cylinders have a height of 8 cm. Cylinder 1 has a radius of 1 cm. Cylinder 2 has a radius of 2 cm. Cylinder 3 has a radius of 3 cm. Find the volume of each cylinder.

Solution

- Cylinder 1 has a volume of $8\pi \approx 25.12 \text{ cm}^3$.
- Cylinder 2 has a volume of $32\pi \approx 100.48 \text{ cm}^3$.
- Cylinder 3 has a volume of $72\pi \approx 226.08 \text{ cm}^3$.

Problem 4

Statement

A one-quart container of tomato soup is shaped like a rectangular prism. A soup bowl shaped like a hemisphere can hold 8 oz of liquid. How many bowls will the soup container fill? Recall that 1 quart is equivalent to 32 fluid ounces (oz).

Solution

4 bowls

(From Unit 5, Lesson 12.)

Problem 5

Statement

Match each set of information about a circle with the area of that circle.

- | | |
|--|-----------------------------------|
| A. Circle A has a radius of 4 units. | 1. 4π square units |
| B. Circle B has a radius of 10 units. | 2. approximately 314 square units |
| C. Circle C has a diameter of 16 units. | 3. 64π square units |
| D. Circle D has a circumference of 4π units. | 4. 16π square units |

Solution

- A: 4
- B: 2
- C: 3
- D: 1

Problem 6

Statement

Two students join a puzzle solving club and get faster at finishing the puzzles as they get more practice. Student A improves their times faster than Student B.

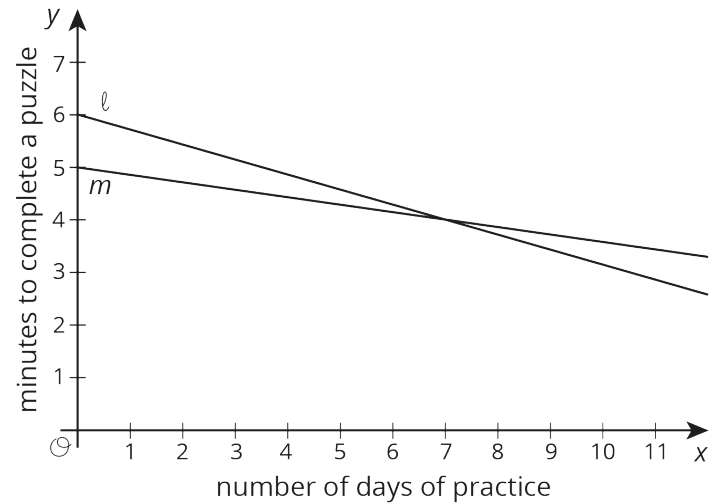

- a. Match the students to the Lines ℓ and m .
- b. Which student was faster at puzzle solving before practice?

Solution

- a. Student A is represented by Line ℓ . Student B is represented by Line m .
- b. Student B

(From Unit 5, Lesson 8.)