

Lesson 8: Area of Triangles

Goals

- Draw a diagram to show that the area of a triangle is half the area of an associated parallelogram.
- Explain (orally and in writing) strategies for using the base and height of an associated parallelogram to determine the area of a triangle.

Learning Targets

- I can use what I know about parallelograms to reason about the area of triangles.

Lesson Narrative

This lesson builds on students' earlier work decomposing and rearranging regions to find area. It leads students to see that, in addition to using area-reasoning methods from previous lessons, they can use what they know to be true about parallelograms (i.e. that the area of a parallelogram is $b \cdot h$) to reason about the area of triangles.

Students begin to see that the area of a triangle is half of the area of the parallelogram of the same height, or that it is the same as the area of a parallelogram that is half its height. They build this intuition in several ways:

- by recalling that two copies of a triangle can be composed into a parallelogram;
- by recognizing that a triangle can be recomposed into a parallelogram that is half the triangle's height; or
- by reasoning indirectly, using one or more rectangles with the same height as the triangle.

They apply this insight to find the area of triangles both on and off the grid.

Alignments

Addressing

- 6.G.A.1: Find the area of right triangles, other triangles, special quadrilaterals, and polygons by composing into rectangles or decomposing into triangles and other shapes; apply these techniques in the context of solving real-world and mathematical problems.

Instructional Routines

- Anticipate, Monitor, Select, Sequence, Connect
- MLR2: Collect and Display
- MLR7: Compare and Connect
- Notice and Wonder

- Think Pair Share

Required Materials

Geometry toolkits

For grade 6: tracing paper, graph paper, colored pencils, scissors, and an index card to use as a straightedge or to mark right angles.

For grades 7 and 8: everything in grade 6, plus a ruler and protractor. Clear protractors with no holes and with radial lines printed on them are recommended.

Notes: (1) "Tracing paper" is easiest to use when it's a smaller size. Commercially-available "patty

paper" is 5 inches by 5 inches and ideal for this. If using larger sheets of tracing paper, consider cutting them down for student use. (2) When compasses are required in grades 6-8 they are listed as a separate Required Material.

Glue or glue sticks

Pre-printed slips, cut from copies of the blackline master

Tape

Required Preparation

Students need access to tape *or* glue; it is not necessary to have both.

Each copy of the blackline master contains two copies of each of parallelograms A, B, C, and D. Prepare enough copies so that each student receives two copies of a parallelogram.

Student Learning Goals

Let's use what we know about parallelograms to find the area of triangles.

8.1 Composing Parallelograms

Warm Up: 10 minutes

This warm-up has two aims: to solidify what students learned about the relationship between triangles and parallelograms and to connect their new insights back to the concept of area.

Students are given a right triangle and the three parallelograms that can be composed from two copies of the triangle. Though students are not asked to find the area of the triangle, they may make some important observations along the way. They are likely to see that:

- The triangle covers half of the region of each parallelogram.
- The base-height measurements for each parallelogram involve the numbers 6 and 4, which are the lengths of two sides of the triangle.
- All parallelograms have the same area of 24 square units.

These observations enable them to reason that the area of the triangle is half of the area of a parallelogram (in this case, any of the three parallelograms can be used to find the area of the triangle). In upcoming work, students will test and extend this awareness, generalizing it to help them find the area of any triangle.

Addressing

- 6.G.A.1

Instructional Routines

- Notice and Wonder
- Think Pair Share

Launch

Display the images of the triangle and the three parallelograms for all to see. Give students a minute to observe them. Ask them to be ready to share at least one thing they notice and one thing they wonder. Give students a minute to share their observations and questions with a partner.

Give students 2–3 minutes of quiet time to complete the activity, and provide access to their geometry toolkits. Follow with a whole-class discussion.

Anticipated Misconceptions

When identifying bases and heights of the parallelograms, some students may choose a non-horizontal or non-vertical side as a base and struggle to find its length and the length of its corresponding height. Ask them to see if there's another side that could serve as a base and has a length that can be more easily determined.

Student Task Statement

Here is Triangle M.

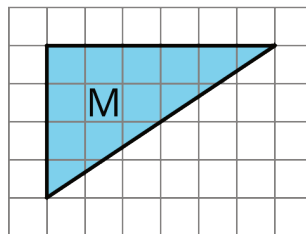

Han made a copy of Triangle M and composed three different parallelograms using the original M and the copy, as shown here.

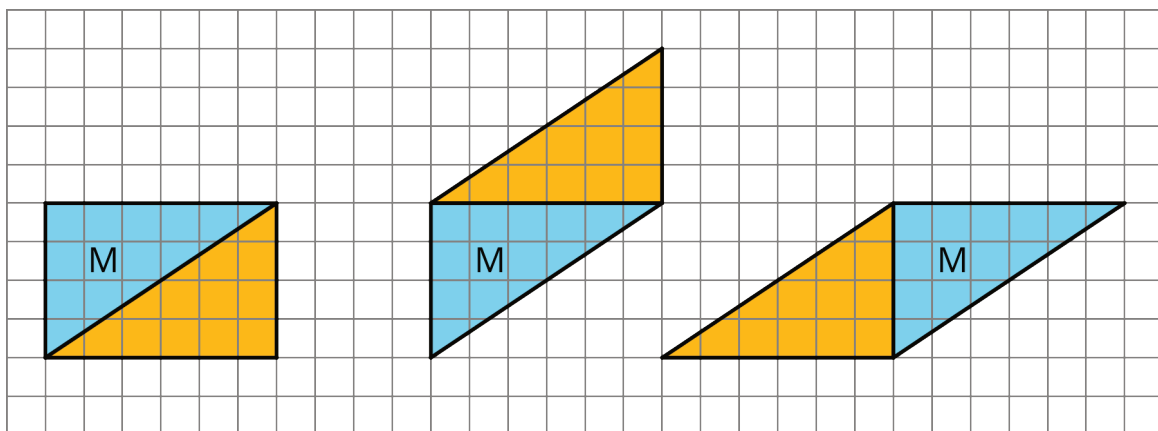

1. For each parallelogram Han composed, identify a base and a corresponding height, and write the measurements on the drawing.
2. Find the area of each parallelogram Han composed. Show your reasoning.

Student Response

1. First parallelogram: $b = 6$ and $h = 4$, second parallelogram: $b = 4$ and $h = 6$, third parallelogram: $b = 6$ and $h = 4$

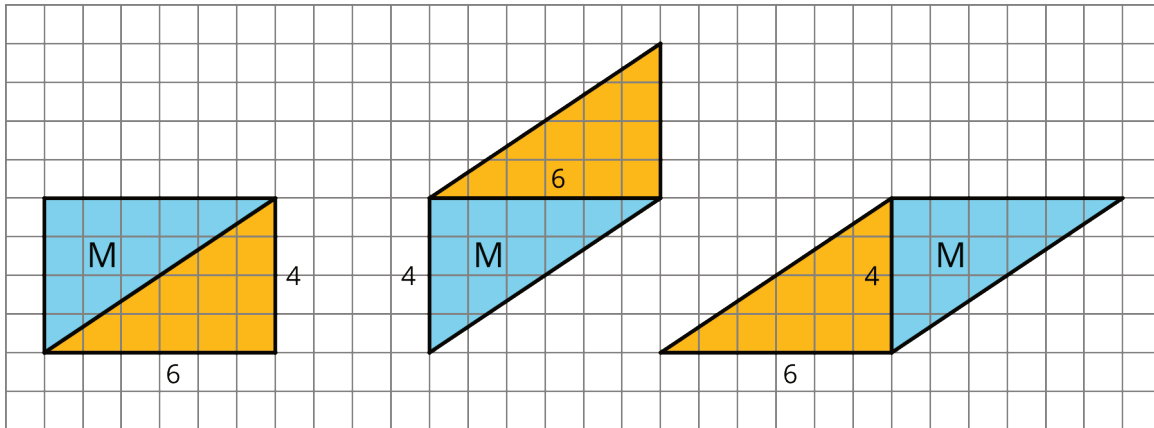

2. The area of all parallelograms is 24 square units. The base and height measurements for the parallelograms are 4 units and 6 units, or 6 units and 4 units. $4 \cdot 6 = 24$ and $6 \cdot 4 = 24$.

Activity Synthesis

Ask one student to identify the base, height, and area of each parallelogram, as well as how they reasoned about the area. If not already brought up by students in their explanations, discuss the following questions:

- “Why do all parallelograms have the same area even though they all have different shapes?” (They are composed of the same parts—two copies of the same right triangles. They have the same pair of numbers for their base and height. They all can be decomposed and rearranged into a 6-by-4 rectangle.)
- “What do you notice about the bases and heights of the parallelograms?” (They are the same pair of numbers.)
- “How are the base-height measurements related to the right triangle?” (They are the lengths of two sides of the right triangles.)
- “Can we find the area of the triangle? How?” (Yes, the area of the triangle is 12 square units because it is half of the area of every parallelogram, which is 24 square units.)

8.2 More Triangles

25 minutes

In this activity, students apply what they have learned to find the area of various triangles. They use reasoning strategies and tools that make sense to them. Students are not expected to use a formal procedure or to make a general argument. They will think about general arguments in an upcoming lesson.

Here are some anticipated paths students may take, from more elaborate to more direct. Also monitor for other approaches.

- Draw two smaller rectangles that decompose the given triangle into two right triangles. Find the area of each rectangle and take half of its area. Add the areas of the two right triangles. (This is likely used for B and D.)
For Triangle C, some students may choose to draw two rectangles around and on the triangle (as shown here), find half of the area of each rectangle, and *subtract* one area from the other.

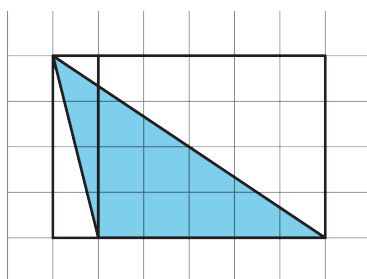

- Enclose the triangle with one rectangle, find the area of the rectangle, and take half of that area. (This is likely used for right triangle A.)
- Duplicate the triangle to form a parallelogram, find the area of the parallelogram, and take half of its area. (Likely used with any triangle.)

Monitor the different strategies students use. Consider asking each student that uses a unique strategy to create a visual display of their work and to share it with the class later.

Addressing

- 6.G.A.1

Instructional Routines

- Anticipate, Monitor, Select, Sequence, Connect
- MLR2: Collect and Display

Launch

Tell students that they will now apply their observations from the past few activities to find the area of several triangles. Arrange students in groups of 2–3. Give students 6–8 minutes of quiet work time and a few more minutes to discuss their work with a partner. Ask them to confer with their group only after each person has attempted to find the area of at least two triangles. Provide access to their geometry toolkits (especially tracing paper).

Access for Students with Disabilities

Representation: Internalize Comprehension. Use color and annotations to illustrate student strategies. As students describe how they calculated the area of each triangle, use color and annotations to scribe their thinking on a display. Ask students how they knew which measurements to use, and label each base and height accordingly.

Supports accessibility for: Visual-spatial processing; Conceptual processing

Access for English Language Learners

Representing, Conversing: MLR2 Collect and Display. Use this routine to collect the initial language and representations students produce when finding the area of a triangle prior to formalizing a formula. As students work through the questions, circulate and observe the various strategies they use to find area. Take pictures of different strategies or sketch them onto a display. Look for students who decompose triangles, or who enclose triangles in a rectangle. While students confer with a partner, continue to add examples of student language to the display. During the whole-class discussion, invite students to borrow language from this display to help them explain their thinking.

Design Principle(s): Support sense-making; Maximize meta-awareness

Anticipated Misconceptions

At this point students should not be counting squares to determine area. If students are still using this approach, steer them in the direction of recently learned strategies (decomposing, rearranging, enclosing, or duplicating).

Students may not recognize that the vertical side of Triangle D could be the base and try to measure the lengths the other sides. If so, remind them that any side of a triangle can be the base.

Student Task Statement

Find the areas of at least two of these triangles. Show your reasoning.

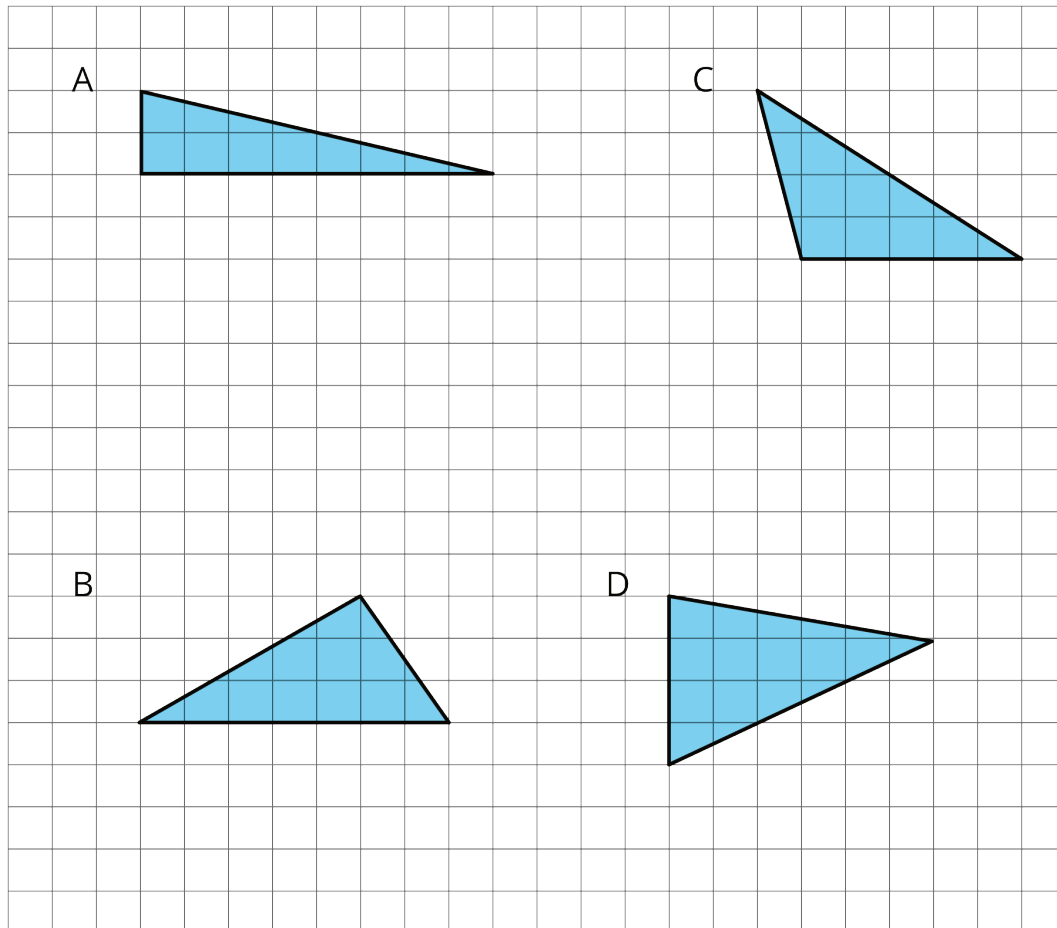

Student Response

Diagrams and explanations vary. Sample responses:

A: 8 square units. $8 \cdot 2 = 16$, so the area of the rectangle is 16 square units. The area of the triangle is half of that of the rectangle, so it is 8 square units.

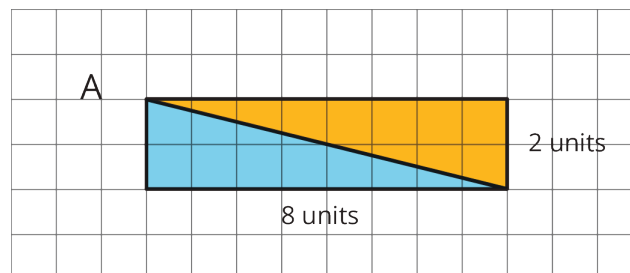

B: 10.5 square units. $5 \cdot 3 = 15$, so the area of the left rectangle is 15 square units. The area of the left triangle is then 7.5 square units. $2 \cdot 3 = 6$, so the area of the right rectangle is 6 square units, so area of the right triangle is 3 square units. The sum of the areas of the small triangles which make up the large triangle is $7.5 + 3 = 10.5$, so the large triangle has area 10.5 square units.

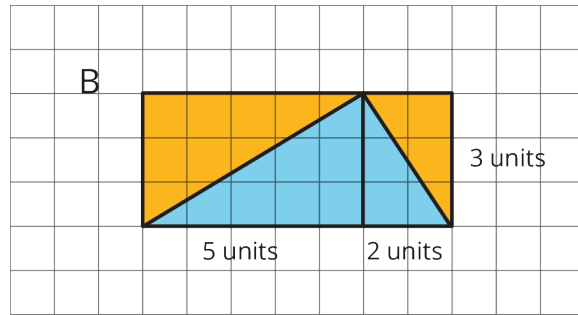

C: 10 square units. If we make a copy of the triangle, rotate it, and join them along the longest side we would get a parallelogram. The base length is 5 units and the height is 4 units, so the area of the parallelogram is 20 square units. The area of the triangle is half of that area, so it is 10 square units.

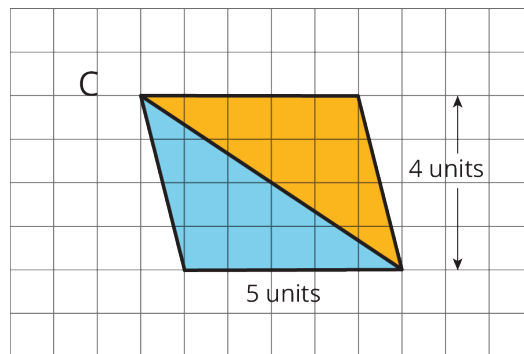

D: 12 square units. Decompose the triangle into a trapezoid and a small triangle by drawing a vertical line 3 units from the left side. Rotate the small triangle to line up with the bottom side of the trapezoid to create a parallelogram. To get the area of that parallelogram: $4 \cdot 3 = 12$.

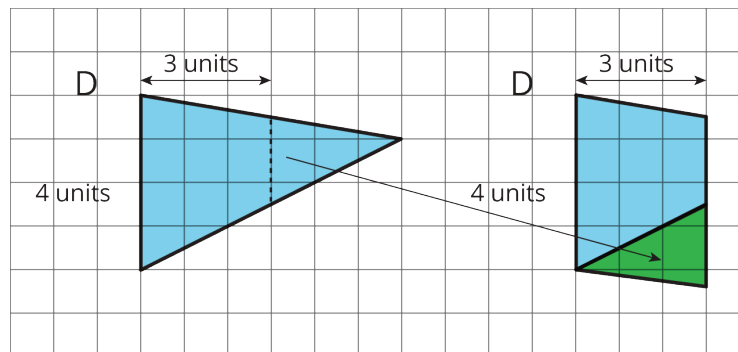

Activity Synthesis

Though students may have conferred with one or more partners during the task, take a few minutes to come together as a class so that everyone has a chance to see a wider range of approaches.

Select previously identified students to explain their approach and display their reasoning for all to see. Start with the most-elaborate strategy (most likely a strategy that involves enclosing a triangle), and move toward the most direct (most likely duplicating the triangle to compose a parallelogram). After each student presents, ask the class:

- “Did anyone else reason the same way?”
- “Did anyone else draw the same diagram but think about the problem differently?”
- “Can this strategy be used on another triangle in this set? Which one?”
- “Is there a triangle for which this strategy would *not* be helpful? Which one, and why not?”

8.3 Decomposing a Parallelogram

Optional: 25 minutes

By now students have more than one path for finding the area of a triangle. This optional activity offers one more lens for thinking about the relationship between triangles and parallelograms. Previously, students duplicated triangles to compose parallelograms. Here they see that a different set of parallelograms can be created from a triangle, not by duplicating it, but by *decomposing* it.

Students are assigned a parallelogram to be cut into two congruent triangles. They take one triangle and decompose it into smaller pieces by cutting along a line that goes through the midpoints of two sides. They then use these pieces to compose a new parallelogram (two parallelograms are possible) and find its area.

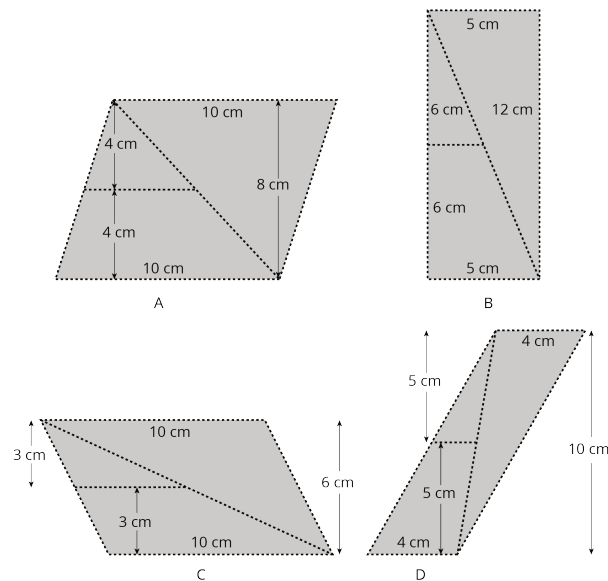

Students notice that the height of this new parallelogram is half of the original parallelogram, and the area is also half of that of the original parallelogram. Because the new parallelogram is composed of the same parts as a large triangle, the area of triangle is also half of that of the original parallelogram. This reasoning paves another way to understand the formula for the area of triangles.

Of the four given parallelograms, Parallelogram B is likely the most manageable for students. When decomposed, its pieces (each with a right angle) resemble those seen in earlier work on parallelograms. Consider this as you assign parallelograms to students.

Addressing

- 6.G.A.1

Instructional Routines

- MLR7: Compare and Connect

Launch

Tell students that they will investigate another way in which triangles and parallelograms are related. Arrange students in groups of 2–4. Assign a different parallelogram from the blackline master to each student in the group. Give each student two copies of the parallelogram and access to a pair of scissors and some tape or glue.

Each parallelogram shows some measurements and dotted lines for cutting. For the first question, students who have parallelograms C and D should *not* cut off the measurements shown outside of the figures.

Give students 10 minutes to complete the activity, followed by a few minutes to discuss their work (especially the last three questions). Ask students who finish early to find someone with the same original parallelogram and compare their work.

Access for Students with Disabilities

Action and Expression: Internalize Executive Functions. Chunk this task into more manageable parts to support students who benefit from support with organizational skills. For example, reveal only one question at a time, pausing to check for understanding before moving on.
Supports accessibility for: Organization; Attention

Anticipated Misconceptions

Students may struggle to form a new parallelogram because the two composing pieces are not both facing up (i.e. either the triangle or the trapezoid is facing down). Tell them that the shaded side of the cut-outs should face up.

Students may struggle to use the appropriate measurements needed to find the area of the parallelogram in the first question. They may multiply more numbers than necessary because the measurements are given. If this happens, remind them that only two measurements (base and height) are needed to determine the area of a parallelogram.

Student Task Statement

1. Your teacher will give you two copies of a parallelogram. Glue or tape *one* copy of your parallelogram here and find its area. Show your reasoning.

- Decompose the second copy of your parallelogram by cutting along the dotted lines. Take *only* the small triangle and the trapezoid, and rearrange these two pieces into a different parallelogram. Glue or tape the newly composed parallelogram on your paper.
- Find the area of the new parallelogram you composed. Show your reasoning.
- What do you notice about the relationship between the area of this new parallelogram and the original one?
- How do you think the area of the large triangle compares to that of the new parallelogram: Is it larger, the same, or smaller? Why is that?
- Glue or tape the remaining large triangle to your paper. Use any part of your work to help you find its area. Show your reasoning.

Student Response

Parallelogram A:

1. 80 sq cm. $10 \cdot 8 = 80$.

2.

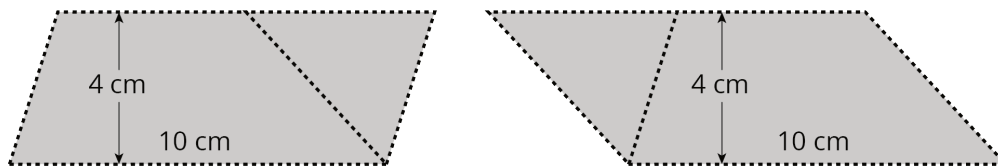

3. 40 sq cm. $10 \cdot 4 = 40$.

Parallelogram B:

1. $5 \cdot 12 = 60$.

2.

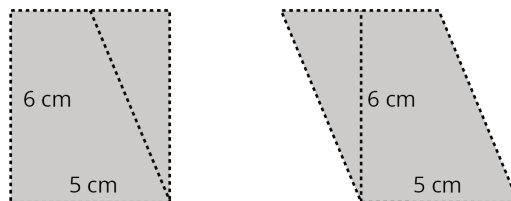

3. 30 sq cm. $5 \cdot 6 = 30$.

Parallelogram C:

1. 60 sq cm. $10 \cdot 6 = 60$.

2.



3. 30 sq cm. $10 \cdot 3 = 30$.

Parallelogram D:

1. 40 sq cm. $4 \cdot 10 = 40$.

2.

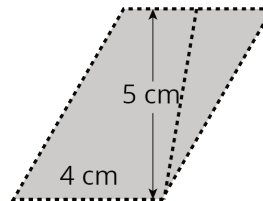
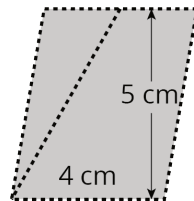

3. 20 sq cm. $4 \cdot 5 = 20$.

All Parallelograms:

1. The area of the new parallelogram is half the area of the original one.
2. Answers vary. Sample responses:
 - The area of the large triangle is the same as that of the new parallelogram. I know that because the trapezoid and little triangle together can be arranged into a triangle that is identical to the large triangle.
 - The new parallelogram and the large triangle have the same area since they are two halves of the original parallelogram.
3. Answers vary. Sample responses:
 - The large triangle in Parallelogram A has an area of 40 sq cm since that is the area of the new parallelogram.
 - The large triangle in Parallelogram D has an area of 20 sq cm since it is half of the original parallelogram, which has an area of 40 sq cm.

Are You Ready for More?

Can you decompose this triangle and rearrange its parts to form a rectangle? Describe how it could be done.

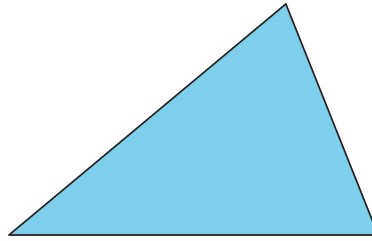

Student Response

Answers vary. Cutting the triangle at half its height, parallel to the base, creates a parallelogram, then another cut helps create a rectangle.

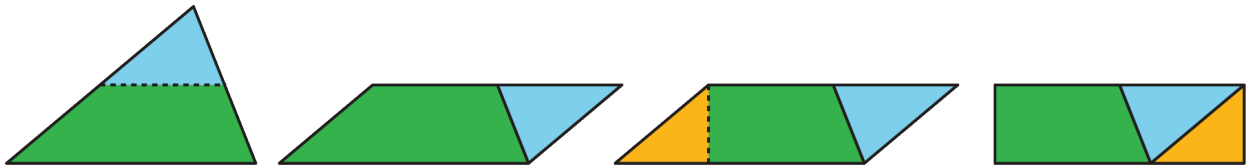

Activity Synthesis

For each parallelogram, invite a student to share with the class their new parallelogram (their answer to the second question). Then, ask if anyone who started with the same original figure created a different, new parallelogram. If a student created a different one, ask them to share it to the class. After all four parallelograms have been presented, discuss:

- “How many possible parallelograms can be created from each set of trapezoid and triangle?”
- “Do they all yield the same area? Why or why not?”
- “How does the area of the new parallelogram relate to the area of the original parallelogram?” (It is half the area of the original.) Why do you think that is?” (The new parallelogram is decomposed and rearranged from a triangle that is half of the original parallelogram. The original and new parallelograms have one side in common (they have the same length), but the height of the new parallelogram is half of that of the original.)
- “Can the area of the large triangle be determined? How?” (Yes. It has the same area as the new parallelogram because it is composed of the same pieces.)

If not already observed by students, point out that, just as in earlier investigations, we see that:

- The area of a triangle is half of that of a related parallelogram that share the same base.
- The triangle and the related parallelogram have at least one side in common.

Access for English Language Learners

Speaking, Listening: MLR7 Compare and Connect. Select students who use varying approaches to the last question to share their reasoning with the class and display their work for all to see. Ask “What is the same and what is different among the different approaches?” Listen for and amplify students’ use of mathematical language (e.g., triangle, parallelogram, trapezoid) and relationships (e.g., “half of”, “same as”). These exchanges strengthen students’ mathematical language use and reasoning.

Design Principle(s): Optimize meta-awareness; Support sense-making

Lesson Synthesis

In this lesson, we practiced using what we know about parallelograms to reason about areas of triangles. We duplicated a triangle to make a parallelogram, decomposed and rearranged a triangle into a parallelogram, or enclosed a triangle with one or more rectangles.

- “What can we say about the area of a triangle and that of a parallelogram with the same height?” (The area of the triangle is half of the area of the related parallelogram.)
- “In the second activity, we cut a triangle along a line that goes through the midpoints of two sides and rearranged the pieces into a parallelogram. What did we notice about the area and the height of the resulting parallelogram?” (It has the same area as the original triangle but half its height.)
- “How might we start finding the area of any triangle, in general?” (Start by finding the area of a related parallelogram whose base is also a side of the triangle.)

8.4 An Area of 14

Cool Down: 5 minutes

Students have explored several ways to reason about the area of a triangle. This cool-down prompts them to articulate at least one way to do so. Not all methods will be equally intuitive or clear to them. In writing a commentary about at least one approach, students can show what makes sense to them at this point.

Addressing

- 6.G.A.1

Student Task Statement

Elena, Lin, and Noah all found the area of Triangle Q to be 14 square units but reasoned about it differently, as shown in the diagrams. Explain *at least one* student’s way of thinking and why his or her answer is correct.

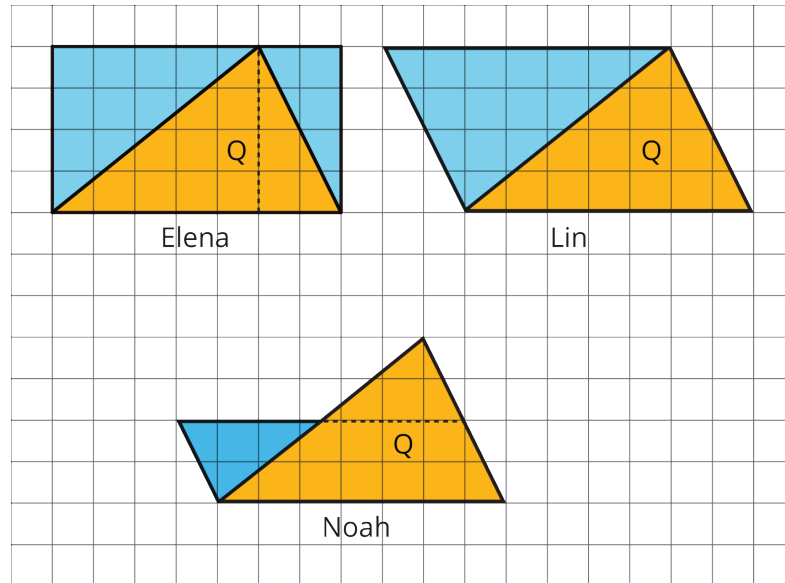

Student Response

Explanations vary. Sample responses:

- Elena drew two rectangles that decomposed the triangle into two right triangles. She found the area of each right triangle to be half of the area of its enclosing rectangle. This means that the area of the original triangle is the sum of half of the area of the rectangle on the left and half of the rectangle on the right. Half of $(4 \cdot 5)$ plus half of $(4 \cdot 2)$ is $10 + 4$, so the area is 14 square units.
- Lin saw it as half of a parallelogram with the base of 7 units and height of 4 units (and thus an area of 28 square units). Half of 28 is 14.
- Noah decomposed the triangle by cutting it at half of the triangle's height, turning the top triangle around, and joining it with the bottom trapezoid to make a parallelogram. He then calculated the area of that parallelogram, which has the same base length but half the height of the triangle. $7 \cdot 2 = 14$, so the area is 14 square units.

Student Lesson Summary

We can reason about the area of a triangle by using what we know about parallelograms. Here are three general ways to do this:

- Make a copy of the triangle and join the original and the copy along an edge to create a parallelogram. Because the two triangles have the same area, one copy of the triangle has half the area of that parallelogram.

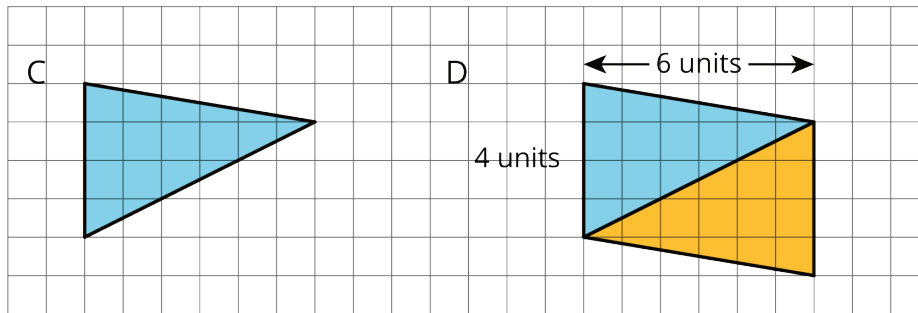
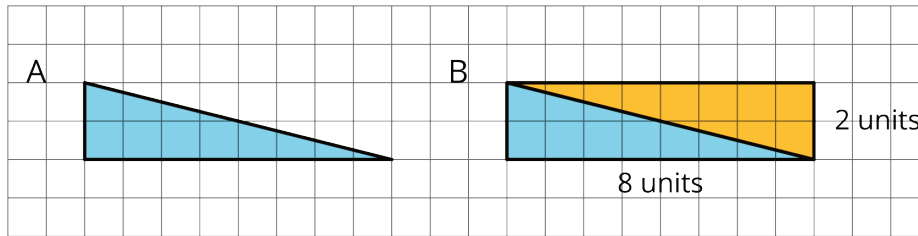

The area of Parallelogram B is 16 square units because the base is 8 units and the height 2 units. The area of Triangle A is half of that, which is 8 square units. The area of Parallelogram D is 24 square units because the base is 6 units and the height 4 units. The area of Triangle C is half of that, which is 12 square units.

- Decompose the triangle into smaller pieces and compose them into a parallelogram.

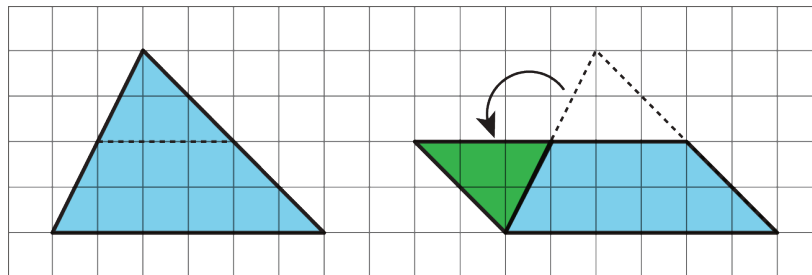

In the new parallelogram, $b = 6$, $h = 2$, and $6 \cdot 2 = 12$, so its area is 12 square units. Because the original triangle and the parallelogram are composed of the same parts, the area of the original triangle is also 12 square units.

- Draw a rectangle around the triangle. Sometimes the triangle has half of the area of the rectangle.

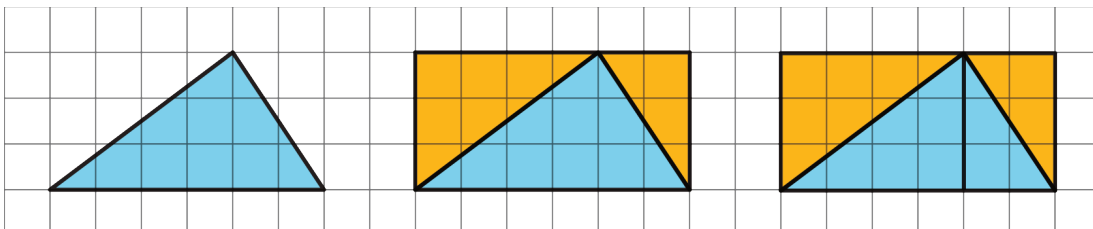

The large rectangle can be decomposed into smaller rectangles. The one on the left has area $4 \cdot 3$ or 12 square units; the one on the right has area $2 \cdot 3$ or 6 square units. The large triangle is also decomposed into two right triangles. Each of the right triangles is half of a smaller rectangle, so their areas are 6 square units and 3 square units. The large triangle has area 9 square units.

Sometimes, the triangle is half of what is left of the rectangle after removing two copies of the smaller right triangles.

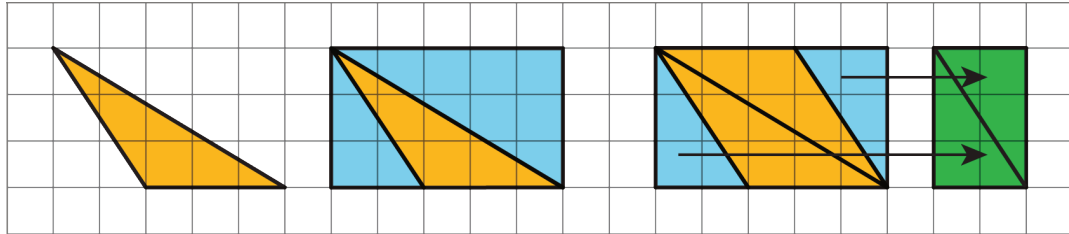

The right triangles being removed can be composed into a small rectangle with area $(2 \cdot 3)$ square units. What is left is a parallelogram with area $5 \cdot 3 - 2 \cdot 3$, which equals $15 - 6$ or 9 square units. Notice that we can compose the same parallelogram with two copies of the original triangle! The original triangle is half of the parallelogram, so its area is $\frac{1}{2} \cdot 9$ or 4.5 square units.

Lesson 8 Practice Problems

Problem 1

Statement

To find the area of this right triangle, Diego and Jada used different strategies. Diego drew a line through the midpoints of the two longer sides, which decomposes the triangle into a trapezoid and a smaller triangle. He then rearranged the two shapes into a parallelogram.

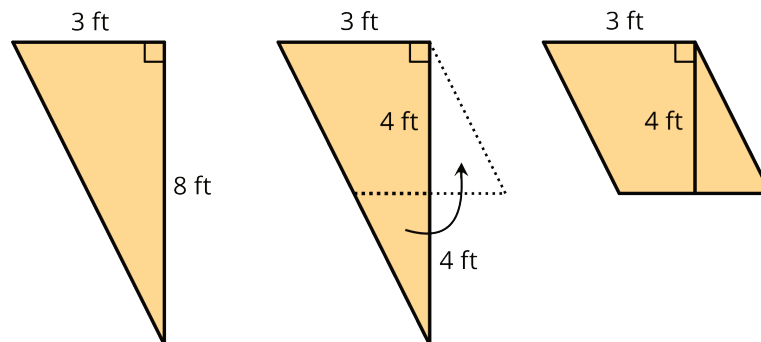

Jada made a copy of the triangle, rotated it, and lined it up against one side of the original triangle so that the two triangles make a parallelogram.

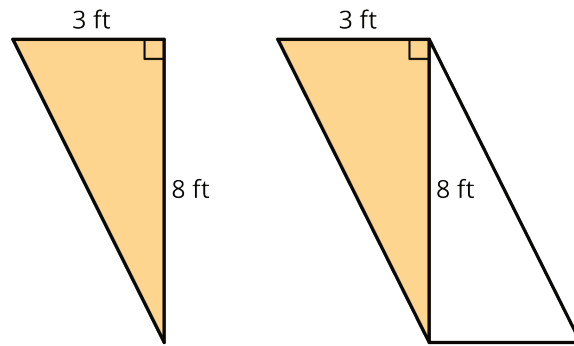

- Explain how Diego might use his parallelogram to find the area of the triangle.
- Explain how Jada might use her parallelogram to find the area of the triangle.

Solution

Answers vary. Sample explanations:

- Diego's parallelogram has a base of 3 feet and a height of 4 feet, so its area is 12 square feet. Because the original right triangle and the parallelogram are composed of the same parts, they have the same area. The area of the triangle is also 12 square feet.
- Jada's parallelogram has a base of 3 feet and a height of 8 feet, so its area is 24 square feet. Because it is composed of two copies of the right triangle, she could divide 24 by 2 to find the area of the triangle. $24 \div 2 = 12$ or 12 square feet.

Problem 2

Statement

Find the area of the triangle. Explain or show your reasoning.

a.

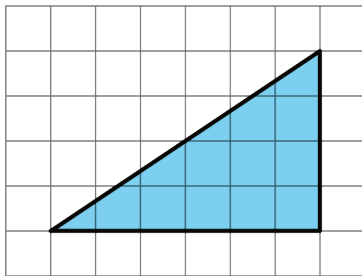

b.

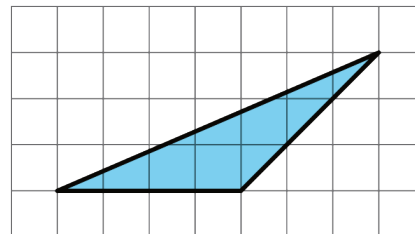

Solution

- 12 square units. Reasoning varies. Sample reasoning: Make a horizontal cut, and rearrange the pieces to make a rectangle. The rectangle is 2 units by 6 units, so its area is 12 square units.

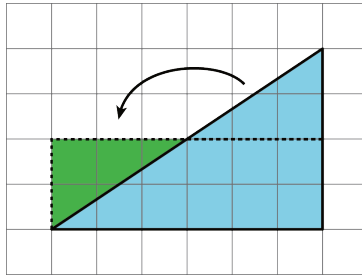

b. 6 square units. reasoning varies. Sample reasoning:

- Duplicate the triangle, and rearrange the pieces to make a parallelogram. The parallelogram has a base of 4 units and a height of 3 units, so its area is 12 square units. Since the parallelogram's area is double the triangle's, the triangle's area is 6 square units.

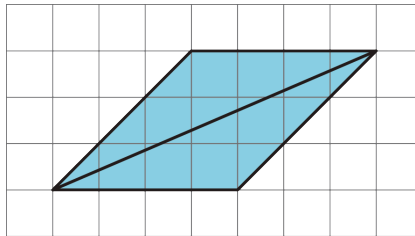

- Decompose the triangle with a cut line half-way between the base and the opposite vertex. Rearrange the smaller triangle to form a parallelogram. This parallelogram has a horizontal base of length 4 units and a height of 1.5 units, so its area is 6 square units. That means the area of the original triangle is 6 square units.

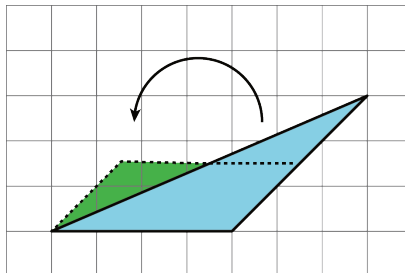

Problem 3

Statement

Which of the three triangles has the greatest area? Show your reasoning. If you get stuck, try using what you know about the area of parallelograms.

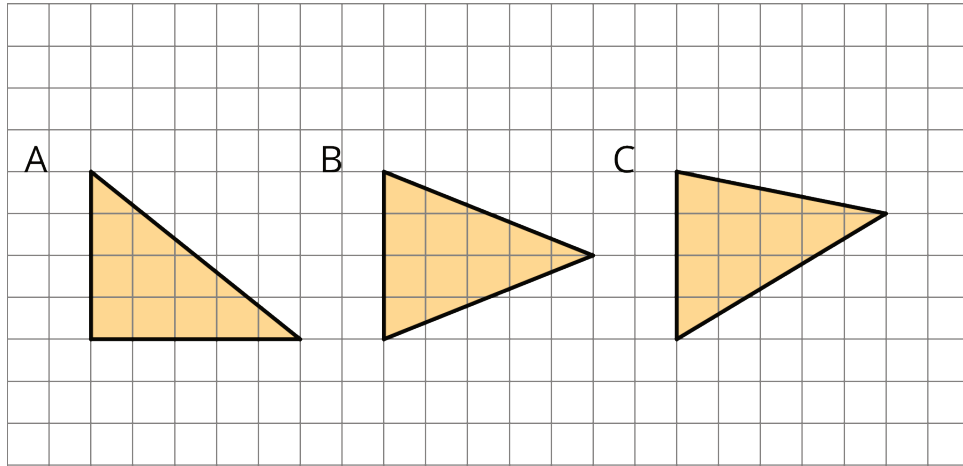

Solution

All three triangles have the same area of 10 square units. Reasoning varies. Sample reasoning: Two identical copies of each triangle can be composed into a parallelogram with a base of 5 units and a corresponding height of 4 units, which means an area of 20 square units. The area of each triangle is half of that of the parallelogram. $\frac{1}{2} \cdot 20 = 10$.

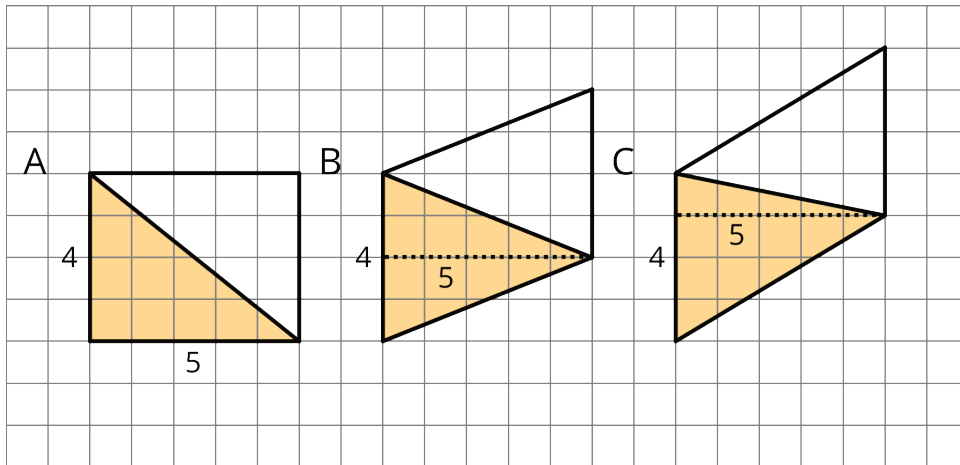

Problem 4

Statement

Draw an identical copy of each triangle such that the two copies together form a parallelogram. If you get stuck, consider using tracing paper.

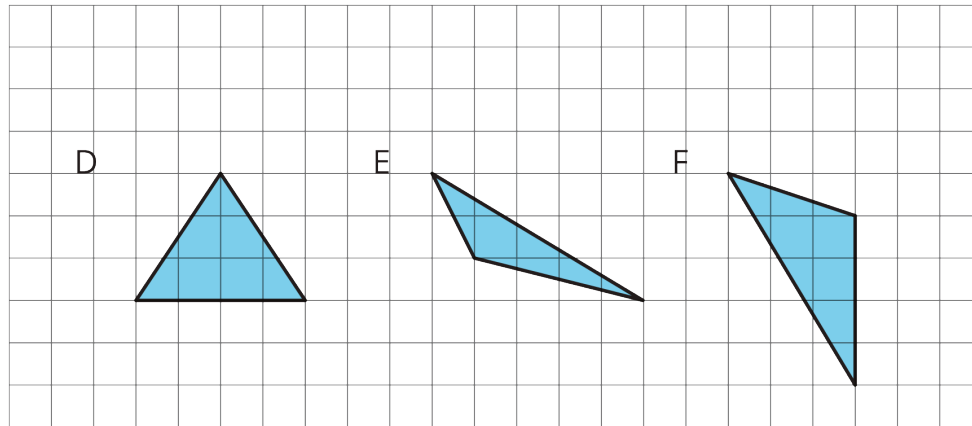

Solution

Answers vary. Sample response:

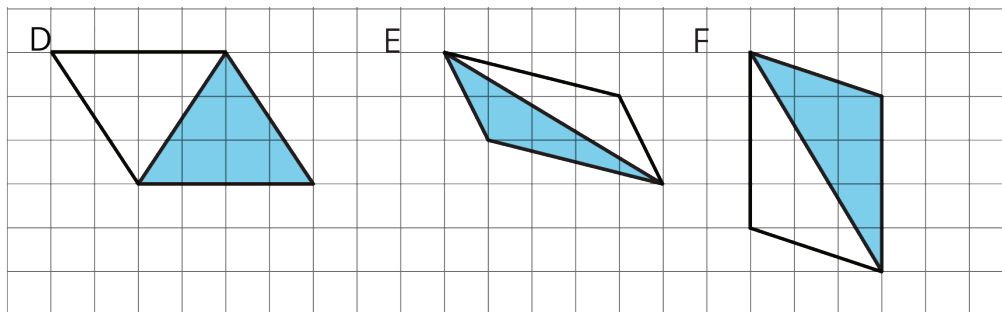

(From Unit 1, Lesson 7.)

Problem 5

Statement

- A parallelogram has a base of 3.5 units and a corresponding height of 2 units. What is its area?
- A parallelogram has a base of 3 units and an area of 1.8 square units. What is the corresponding height for that base?
- A parallelogram has an area of 20.4 square units. If the height that corresponds to a base is 4 units, what is the base?

Solution

- 7 square units
- 0.6 units
- 5.1 units

(From Unit 1, Lesson 6.)