

Lesson 8 Practice Problems

1. This is an invalid proof that all isosceles triangles are similar. Explain which step is invalid and why.
 1. Draw 2 isosceles triangles ABC and DEF where $AC = BC$ and $DF = EF$.
 2. Dilate triangle ABC to a new triangle $A'B'C$ using center C and scale factor $\frac{DF}{AC}$ so that $A'C = B'C = DF = EF$.
 3. Translate by directed line segment CF to take $A'B'C$ to a new triangle $A''B''F$. Since translation preserves distance, $A''F = A'C = DF$ and $B''F = B'C = EF$.
 4. Since $A''F = DF$, we can rotate using center F to take A'' to D .
 5. Since $B''F = EF$, we can rotate using center F to take B'' to E .
 6. We have now established a sequence of dilations, translations, and rotations that takes A to D , B to E , and C to F , so the triangles are similar.

2. Which statement provides a valid justification for why all circles are similar?
 - A. All circles have the same shape—a circle—so they must be similar.
 - B. All circles have no angles and no sides, so they must be similar.
 - C. I can translate any circle exactly onto another, so they must be similar.
 - D. I can translate the center of any circle to the center of another, and then dilate from that center by an appropriate scale factor, so they must be similar.

3. Which pair of polygons is similar?

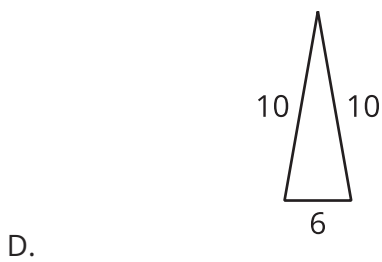
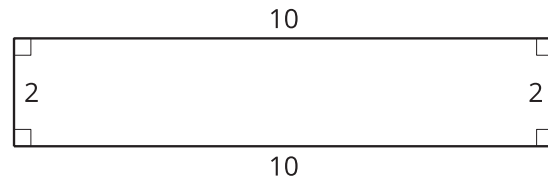
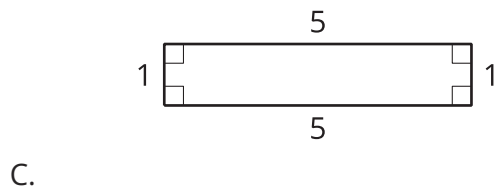
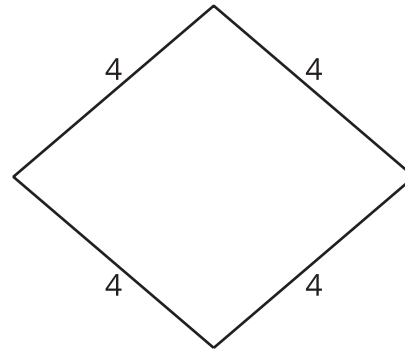
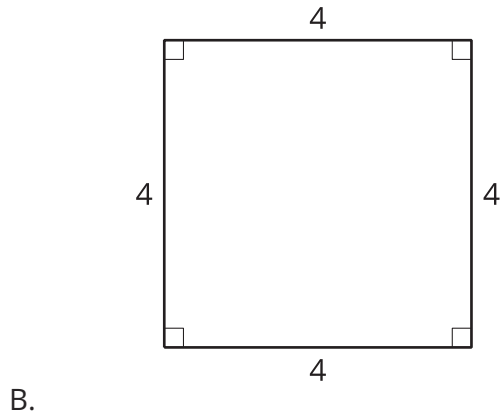
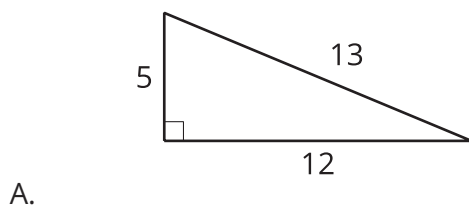

4. Select **all** sequences of transformations that would show that triangles ABC and AED are similar. The length of AC is 6 units.

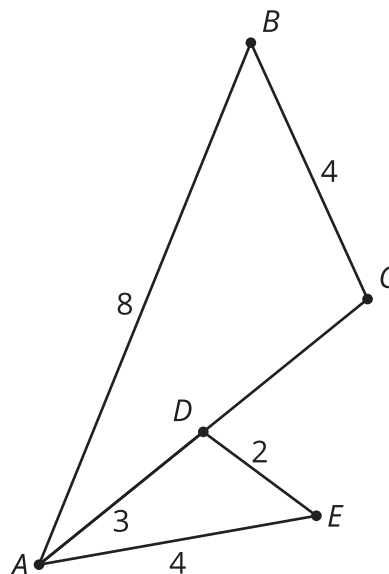

- A. Dilate triangle ABC using center A by a scale factor of $\frac{1}{2}$, then reflect over line AC .
- B. Dilate triangle AED using center A by a scale factor of 2, then reflect over line AC .
- C. Reflect triangle ABC over line AC , then dilate using center A by a scale factor of $\frac{1}{2}$.
- D. Reflect triangle AED over line AC , then dilate using center A by a scale factor of 2.
- E. Translate triangle AED by directed line segment DC , then dilate using center C by scale factor 2.
- F. Translate either triangle ABC or AED by directed line segment DC , then reflect over line AC .

(From Unit 3, Lesson 7.)

5. Determine if each statement must be true, could possibly be true, or definitely can't be true. Explain or show your reasoning.

- a. Two equilateral triangles are similar.
- b. An equilateral triangle and a square are similar.

(From Unit 3, Lesson 7.)

6. Find a sequence of rigid transformations and dilations that takes square $EFGH$ to square $ABCD$.

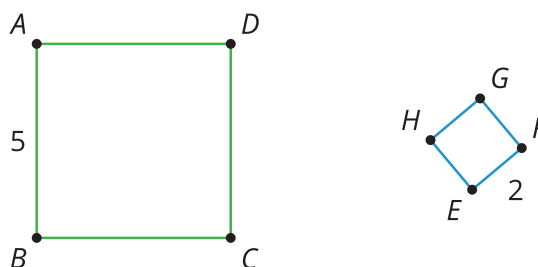

(From Unit 3, Lesson 6.)

7. Select **all** true statements given that angle AED is congruent to angle ABC

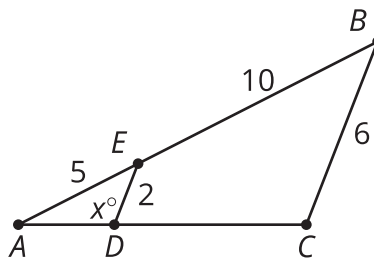

- A. Angle ACB is $180 - x^\circ$
- B. Angle ACB is x°
- C. Triangle ACB is similar to triangle ADE
- D. $AD = \frac{1}{3}AC$
- E. $AD = \frac{1}{2}DC$

(From Unit 3, Lesson 5.)